



Bridge Views



Issue 65 _____ January/February 2011

Inside This Issue...

FHWA's Every Day Counts Initiative

Ultra-High Performance Concrete Waffle Slab Bridge Deck for Wapello County, Iowa

Q & A

FHWA's Every Day Counts Initiative

M. Myint Lwin and Louis N. Triandafilou, Federal Highway Administration



I-15 Prefabricated Bridge Superstructure – Pioneer Crossing, Utah.

For the Nation's highway community, meeting the challenges of today's transportation needs while working more efficiently, sustainably, and cost-effectively means going beyond innovation and ingenuity. It means making every day count. Rapid deployment of proven technology and solutions to speed up project delivery are at the heart of the Federal Highway Administration's (FHWA) new Every Day Counts (EDC) initiative. According to FHWA Administrator Victor Mendez, EDC is designed to identify and deploy innovation aimed at shortening project delivery, enhancing the safety of our roadways, and improving environmental sustainability. EDC will initially focus on getting promising new technologies into the marketplace faster and speeding the delivery of major highway projects. Administrator Mendez has asked FHWA Deputy Administrator Greg Nadeau to lead this initiative.

The FHWA aims to make innovative contracting standard business practice by supporting the deployment of such accelerated project delivery methods as Construction Manager/General Contractor (CM/GC) and Design/Build. The EDC initiative will also provide several innovative approaches to improving the delivery process for projects that require an Environmental Impact Statement (EIS) or other environmental documents. EDC also features the following priority technologies that are intended to be implemented on a fast-track schedule over the next 2 years: warm mix asphalt, adaptive signal control technology, safety edge, geosynthetic reinforced soil integrated bridge system, and prefabricated bridge elements and systems (PBES). Many of today's bridge construction and replacement projects take place in areas of heavy traffic, where detours and bridge closures severely impact the flow of people and goods on transportation corridors. One of the most common ways to acceler-

SPONSORED BY



U.S. Department of Transportation
Federal Highway Administration

CO-SPONSORED BY
NATIONAL CONCRETE BRIDGE COUNCIL



PORTLAND CEMENT ASSOCIATION



PRECAST PRESTRESSED CONCRETE INSTITUTE



NATIONAL READY MIXED CONCRETE ASSOCIATION



AMERICAN SEGMENTAL BRIDGE INSTITUTE



EXPANDED SHALE CLAY AND SLATE INSTITUTE



CONCRETE REINFORCING STEEL INSTITUTE



POST-TENSIONING INSTITUTE



SILICA FUME ASSOCIATION



WIRE REINFORCEMENT INSTITUTE

ate bridge construction is to use PBES to construct bridges. These elements and systems are prefabricated off-site or adjacent to the final bridge alignment ahead of time, and then moved into place when needed, resulting in closure of the bridge and highway for only a short duration. Very frequently, these PBES are constructed using conventionally reinforced, pretensioned, or post-tensioned concrete or a combination thereof, for superstructure and substructure members.

The use of concrete PBES results in several key benefits that fit the EDC initiative, such as reduced on-site construction time; minimal disruption to the traveling public; improved safety of the traveling public, contractor's work crews, and the owner's inspection teams; less disruption to sensitive environments; improved quality of the finished product; and lower initial and life-cycle project costs.

Contractors can improve quality of finished concrete products by prefabricating them in protected environments, thus avoiding harsh weather conditions. In a protected environment, suppliers are able to produce a consistent quality of ready-mixed or precast concrete products. Standardized plant operations result in a consistent quality of production. Within a protected environment, the producer can attain optimal curing of concrete elements, without having to deal with the costly and time-consuming requirements of cold- or hot-weather concreting. Many concrete bridges already employ high performance concrete (HPC)

to enhance durability and may use high strength concrete to achieve longer span lengths and eliminate piers. Thus, the implementation of PBES to accelerate bridge projects is tailor-made to continue the national implementation of HPC that state departments of transportation (DOTs) have been aggressively pursuing.

Depending on the size of the concrete superstructure and substructure PBES, various means and placement techniques can be deployed to accelerate bridge projects. These include the use of self-propelled modular transporters (SPMTs), as depicted in the photograph, longitudinal launching, and transverse sliding or skidding. These techniques are applicable to both single-span and multi-span bridges. For short span structures, which make up the majority of the National Bridge Inventory, conventional equipment can be used.

HPC superstructure and substructure PBES can play an important role in helping the state DOTs achieve the national goals that FHWA is considering as part of the EDC initiative. Two of these goals still in draft form are as follows:

- By December 2012, 100 bridges will have been designed and/or constructed rapidly by using PBES.
- By December 2012, 25% of all single- or multi-span replacement bridges authorized using federal-aid have at least one major prefabricated bridge element that shortens construction time relative to conventional construction.

Summary

FHWA's EDC initiative emphasizes an improved driving experience for the American public, through rapid deployment of several proven technologies and solutions to speed up project delivery with minimal disruption to traffic. PBES using HPC elements will continue to demonstrate that bridges can be built better, faster, and safer, all in a manner that results in beneficial benefit/cost ratios when taking into account road user costs.

(articles continue on next page)

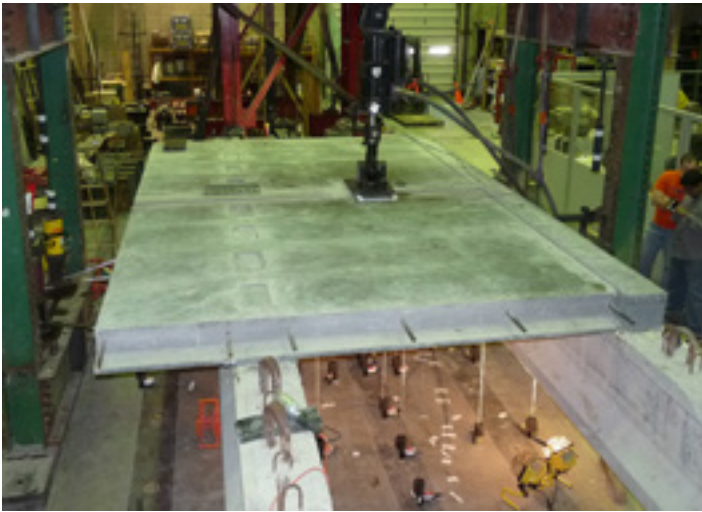

Full scale laboratory tests of the waffle slab system were performed.

Ultra-High Performance Concrete Waffle Slab Bridge Deck for Wapello County, Iowa

Dean Bierwagen, Ping Lu, and Ahmad Abu-Hawash, Iowa Department of Transportation; Brian Moore, Wapello County, Iowa; and Terry Wipf and Sri Sritharan, Iowa State University, Ames, Iowa.

Since 2003, Iowa has been helping expand the knowledge base for the design, casting, and construction of highway bridge components using ultra-high performance concrete (UHPC). With funding support from the Federal Highway Administration's (FHWA) Innovative Bridge Research and Deployment (IBRD) program and the Iowa Highway Research Board (IHRB), two bridge projects have been completed using UHPC. The first was the Mars Hill Bridge, a single-span, 110-ft (33.5-m) long, prestressed I-girder bridge, in Wapello County, Iowa. The three girders of the cross-section were cast with UHPC. The second bridge was the Jakway Park Bridge, a three-span 110-ft (33.5-m) long bridge, in Buchanan County, Iowa. The center 50-ft (15.2-m) long span was constructed with UHPC using the pi-girder cross section developed by the FHWA and the Massachusetts Institute of Technology. More details about these two

projects are given in HPC Bridge Views, Issue No 57.

In keeping with the trend of trying to develop cost-effective bridge sections using UHPC, the FHWA had investigated the potential use of a UHPC waffle deck precast system for bridges and had developed a design procedure for a full-depth deck system. The Iowa Department of Transportation (Iowa DOT), in cooperation with Wapello County, Iowa, and Iowa State University (ISU), sponsored a workshop in Iowa with attendance by representatives of industry, academia, contractors, and the FHWA to discuss the potential for using the UHPC waffle slab in a demonstration bridge. A grant secured by Coreslab Structures of Omaha, Nebraska, from the FHWA's Highways for LIFE program along with research funding from the IHRB, provided the funds to pursue this project. The Iowa DOT, Wapello County, and ISU are now working on a bridge

project where a precast deck will use UHPC in a waffle configuration. Field cast UHPC will be used in the connections between the panels and the girders and between adjacent panels. This article summarizes the project activities through November 2010.

Project Details

The project was divided into two phases. In Phase I, Coreslab Structures completed casting of two test panels at its plant in Bellevue, Nebraska, and ISU performed laboratory testing and evaluation. Following the approval by FHWA of the Phase I work, Phase II of the project began with casting the bridge deck panels in summer and fall 2010. Construction of the test bridge in Wapello County is planned for spring 2011.

Phase I—Design

The Iowa DOT with assistance from ISU designed the waffle deck panels for the bridge. The

required compressive strength for the UHPC was 24,000 psi (165 MPa). The waffle deck design procedure was based on a modified version of the empirical design method of the American Association of State Highway and Transportation Officials (AASHTO) LRFD Bridge Design Specifications. The design was validated through laboratory testing that included a study of the expected performance of the jointed waffle panel system. The demonstration bridge will be 60 ft (18.2 m) long and 33 ft (10 m) wide. The superstructure will consist of five standard Iowa Type B precast, prestressed concrete girders spaced at 7 ft 4 in. (2.23 m). The 8-in. (200-mm) deep waffle slab is designed to be composite with the girders. Steel reinforcement in the panels consists of No. 6 bars. The deck cross section is composed of two precast UHPC waffle deck panels that are connected at the centerline of the bridge. Each panel is 8 ft (2.4 m)

long (measured in the bridge's longitudinal direction) and 16 ft 2½ in. (4.94 m) wide.

Phase I—Testing

Two laboratory specimens representing a full-scale portion of the Wapello County Bridge were tested in the ISU Structural Engineering Laboratories. The laboratory test specimens were designed to simulate service, fatigue, and ultimate loading of the deck panels. Several connection details between the two adjacent decks panels and between the deck panels and the girders were included. The test panels were 8 ft (2.4 m) long (the same lengths as the proposed bridge panels) and 9 ft 9 in (2.97 m) wide. The two panels were placed end-to-end and spanned 7 ft 4 in. (2.23 m) across two 24-ft (7.32-m) long prestressed concrete girders as shown in the drawing at the end of this article.

A single point load was applied to the laboratory specimen at

various locations to represent a wheel load. The loading locations were selected based upon finite element analysis of the test specimen to identify critical locations. The laboratory testing of the UHPC waffle deck system indicated that the waffle deck including the UHPC joint systems performed satisfactorily. No fatigue damage was noted after 1 million cycles of loading at each loading location. Displacements of the bridge deck were considerably smaller than the allowable limits of the AASHTO LRFD Bridge Design Specifications. Further testing will be performed in the field once the bridge is constructed as part of Phase II of the FHWA grant.

Phase II

After successful validation of construction and performance of the waffle deck system in Phase I, the deck panels for the prototype bridge were cast in the summer and fall of 2010. The

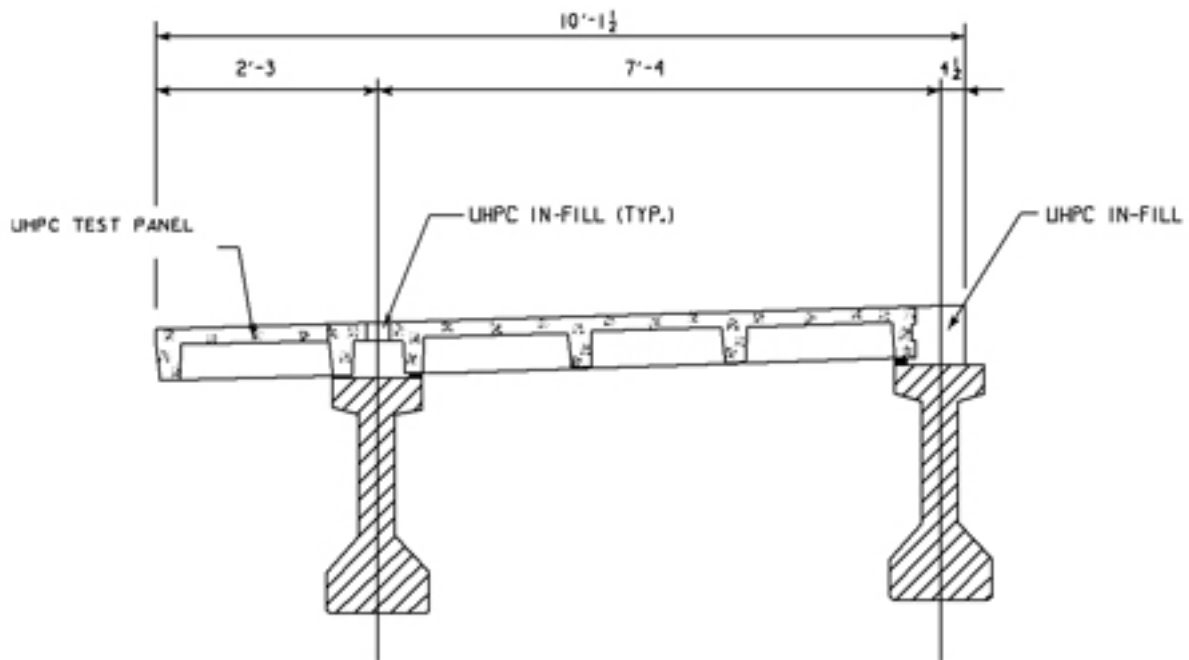

TEST CROSS SECTION

measured compressive strength of the UHPC in the production panels was 33,700 psi (232 MPa). Because of flooding during the summer in Wapello County, bridge construction was delayed until spring 2011. Through the conduct of this study, multiple organizations gained significant knowledge about the design, construction, handling, fabrication, and structural performance of this innovative deck system. Once the Wapello County Bridge is constructed, field testing and evaluation will be performed to provide further information about this new precast deck

Q & A

Question: Can I use the AASHTO LRFD Bridge Design Specifications for specified concrete compressive strengths above 10 ksi (69 MPa)?

Answer: The scope of the Fifth Edition of the American Association of State Highway and Transportation Officials (AASHTO) LRFD Bridge Design Specifications states that the provisions of Section 5: Concrete Structures are based on concrete strengths ranging from 2.4 to 10.0 ksi (17 to 69 MPa), except where higher strengths are allowed for normal weight concrete. Article 5.4.2.1—Compressive Strength of the specifications states that design concrete strengths above 10.0 ksi (69 MPa) for normal weight concrete shall be used only when allowed by specific articles or when physical tests are made to establish the relationships between the concrete strength and other properties. Appendix C5 of the specifications

system. The field data, combined with the laboratory test data, will provide important information for potential use of these deck types in the future and allow design, construction, and fabrication modifications if needed. In addition to the durability benefits of UHPC, the waffle slab concept offers several potential benefits including a viable precast deck alternative for use in accelerated bridge construction of new bridges, and a weight-saving precast deck alternative for use in replacing deteriorated decks on existing bridges.

contains a table showing the articles for which strengths above 10.0 ksi (69 MPa) are currently permitted. These include Articles 5.4.2.3—Shrinkage and Creep; 5.4.2.4—Modulus of Elasticity; 5.4.2.6—Modulus of Rupture; and 5.9.5—Loss of Prestress.

Three National Cooperative Highway Research Program (NCHRP) projects have been completed to address other design provisions.⁽¹⁻³⁾

NCHRP Report No. 579⁽¹⁾ addresses design for shear and confirms that the existing provisions of Article 5.8.3—Sectional Design Method are applicable for normal weight concrete with specified concrete compressive strengths up to 18.0 ksi (124 MPa).

NCHRP Report No. 595⁽²⁾ addresses design for flexure and compression and recommends some fine tuning of the existing provisions to make them applicable for normal weight concrete with specified com-

References

Garcia, H. M., "Analysis of an Ultra-High Performance Concrete Two-Way Ribbed Bridge Deck Slab." Federal Highway Administration, Report No. FHWA-HRT-07-056, 2007, 64 pp.

More Information

More information about this Iowa project and UHPC is available in the above document and at www.fhwa.dot.gov/hfl/partnerships/coreslab/phase1/app_index.cfm or contact the lead author at dean.bierwagen@dot.iowa.gov.

pressive strengths up to 18.0 ksi (124 MPa). The fine tuning includes modifications to Equation 5.4.2.3.2-5 for time-development factor; Equation 5.4.2.4-1 for modulus of elasticity; Article 5.4.2.6 for modulus of rupture; Article 5.7.2.2 for equivalent rectangular stress distribution; a new article 5.7.3.2.6 on nominal flexural resistance; and Equation 5.7.4.2-3 for minimum area of longitudinal reinforcement.

NCHRP Report No. 603⁽³⁾ addresses transfer length and development length for prestressing strand and development length and splice length for non-prestressed deformed reinforcement. For prestressing strands, the research confirmed that existing provisions for transfer length and development length are applicable for normal weight concrete with specified compressive strengths up to 15.0 ksi (103 MPa) but overestimate the required lengths. Modifica-

tions to the existing provisions are proposed in the report to reflect shorter lengths as concrete strength increases.

For development length and splice length of non-prestressed reinforcement, the report recommends that the provisions be extended up to a specified concrete compressive strength of 15.0 ksi (103 MPa) using a format similar to the American Concrete Institute's (ACI) building code ACI 318-05.⁽⁴⁾

The three research projects provide revisions to allow more provisions to be extended to specified concrete compressive strengths above 10.0 ksi (69 MPa) for normal weight concrete. These revisions, however, do not become the official specification articles until approved by the AASHTO Highway Subcommittee on Bridges and Structures and published by AASHTO.

References

1. Hawkins, N. M. and Kuchma, D. A., "Application of LRFD Bridge Design Specifications to High-Strength Concrete: Shear Provisions," Transportation Research Board, NCHRP Report 579, Washington, DC, 2007, 197 pp.
2. Rizkalla, S., Mirmiran, A., Zia, P., Russell, H., and Mast, R., "Application of the LRFD Bridge Design Specifications to High-Strength Structural Concrete: Flexure and Compression Provisions," Transportation Research Board, NCHRP Report 595, Washington, DC, 2007, 28 pp.
3. Ramirez, J. A. and Russell, B. W., "Transfer, Development, and Splice Length for Strand/Reinforcement in High-Strength Concrete," Transportation Research Board, NCHRP Report 603, Washington, DC, 2008, 122 pp.